

BALTOGRAPH **XSD160/4KW**



High voltage range:	5 to 160 kV
Tube current range:	0,1 to 50 mA
Focal spot size:	From 0,2 x 0,2 to 3 x 3
Max. output power:	4000 W
Anode cooling type:	Water
Duty cycle:	100%
Insulation:	Encapsulated
Voltage:	230 V
Operating temperature:	45°C
Weight:	68 kg
Tubehead:	Metal Ceramic
Control Unit:	LS1

MAIN FEATURES

- High frequency constant potential generator
- « Ripple free »
- High duty cycle
- Current up to 50 mA
- Metal-ceramic tube
- Stationary or mobile unit
- Full automatic preheating
- Very stable output
- Safety first, X-ray start with 2 buttons
- Low consumption



KEY ADVANTAGES

- Very reliable
- Powerful, steadiness & sturdiness
- Solid insulation HV module : more convenient for the maintenance
- No gas and no oil to isolate
- Can be turned into panoramic or directional x-ray equipment
- Can drive up to two individual filament
- Can be combined to a RS232 interface
- CANON military metallic connectors

MOST COMMON APPLICATIONS

- Oil & Gas
- Energy
- Aeronautical/ aerospace
- Transport
- Military
- Bio-medical & agriculture
- And much more



Introducing the Baltograph series, the XSD160 is the first unit of a complete set based on a solid insulation HV module.

Completely renewed during summer 2014, it keeps all previous features but has been made with the latest available components, reduced in size, weight and the most important, is more powerful, offering 4000W & up to 50 mA. This technology not only frees you from very specialized service operations but also guarantees that you will be able to get the most out of your machine at any time.

The XSD160 is a very powerful, stable and sturdy unit that can be used as a mobile unit or a fixed one in any customized systems for production.

Combined to our computerized control panel (LS1) or to a dedicated RS232 interface through an interfacing box, it can

MECHANICAL DRAWING

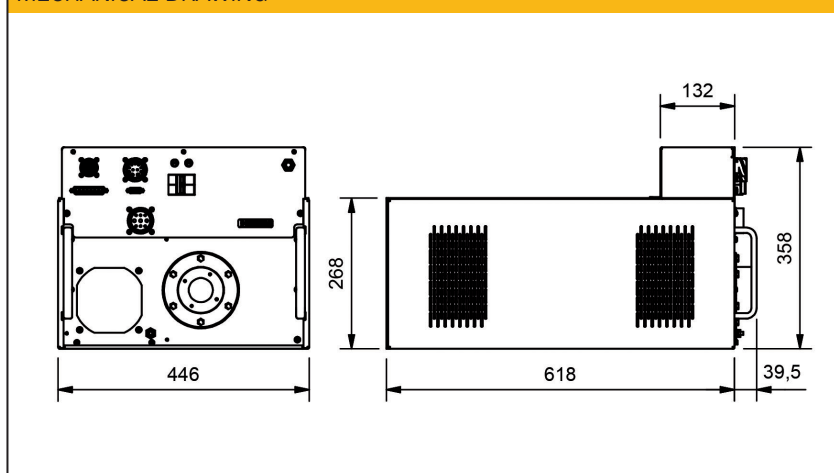

be integrated in all kind of environment, can replace the majority of existing units without big changes or any, or can be installed as a single end unit, stationary or mobile (XMD).

INTERNATIONAL

- CE certified
- NFC74-100 LCIE Certified

Specifications	Units	XSD160/4KW
High voltage range	kV	5 to 160
Tube current range	mA	0,1 to 50
Focal spot size (IEC336)		From 0,2 x 0,2 to 3 x 3
Ripple		0,1% PP
Maximum output power	Watt	4000
Frequency	Hz	47 - 63
Current	A	18
Steel penetration at max (*)	mm	35
Working temperature	°C	0 to 45°C
Anode cooling type		Water
Duty cycle	%	100%
Insulation		Encapsulated
Voltage	V	230 (-15% +10%)
Weight	Kg	68
Tubehead		Metal-Ceramic
Control unit:		LS1

* FFD= 700mm/Film Carestream Industrex AA400/D=2.0/t=10min.



LS1

- kV step: **1 - 2 - 5**
- mA step: **0,1 - 0,2 - 0,5**
- Memories: **10.000**
- Casing: **Aluminium**
- Frequency: **45 - 66 Hz**
- Mains: **90 - 245 V**
- Weight: **4,8kg**

STANDARD EQUIPMENT

- X-Ray generator : XSD or CLD
- Tubehead : TSD or TSC
- Control unit : LS1 or LS1C
- A cable from the generator to the control panel
- A main power cable



LS1-C2

- kV step: **1 - 2 - 5**
- mA step: **0,1 - 0,2 - 0,5**
- Memories: **10.000**
- Casing: **Aluminium**
- Frequency: **45 - 66 Hz**
- Mains: **90 - 245 V**

OPTIONAL EQUIPMENT

- Warning flashing light with 20 m cable
- Closed circuit type water cooling unit
- Water security box

Produced by:

Balteau NDT

Rue Voie de Liège, 12
B-4681 Hermalle Sous Argenteau
Belgium

www.balteau.com

balteau@balteau.com

Tel. +32 (0) 4 374 75 75

Fax +32 (0) 4 374 75 85

Distributed by:

