

NORDINKRAFT NDT-GROUP
EQUIPMENT FOR AUTOMATED
ULTRASONIC TESTING OF
BARS AND BILLETS



EMATEST[®]-BB



ULTRASONIC TESTING OF BARS AND BILLETS

Ultrasonic testing (UT) of bars and billets is a pressing problem to be solved by the metallurgical industry. Manual testing of the above mentioned products is practically impossible because they are manufactured in large quantities, have complicated geometry and a wide range of important uses. Moreover, they have to conform to the strict requirements of modern quality standards.

Today a steel maker that manufactures round bars and square billets and has an ambition of becoming a quality producer cannot do without an automated ultrasonic testing line.

However, the presence of test equipment does not ensure the absence of flaws and high quality of metal products.

By their location defects typical for bars and billets can be divided into three groups:

- Surface (located immediately on the surface of a test object).
- Subsurface (located immediately under the surface of a test object).
- Internal (that are found at least 2-5 mm deep under the surface of a material).

Detection of internal flaws is quite a difficult yet classical task for ultrasonic testing methods. Besides NORDINKRAFT, there are several companies in the world, which offer automated ultrasonic testing equipment that is capable of detecting internal defects in bars and billets. At that, most manufacturers of such UT equipment use piezoelectric transducers that emit and receive ultrasound through a coupling medium.

As for surface and subsurface defects, their detection in production conditions with the use of the piezoelectric transducer seems to be a problematic task.

The point is that any coupling medium «loads» the test object's surface and, thus, influences the parameters and the distribution pattern of acoustic fields. As a rule, this causes superfluous rejection of materials.

A couplant's influence is especially high when one excites elastic vibrations at an angle. In fact, the application of piezoelectric transducers due to the negative influence of a coupling medium makes questionable the use of Rayleigh waves in industrial conditions. This is rather a problem because it is the type of waves that is most sensitive to surface flaws.

Moreover, a coupling medium may change physical properties of surface discontinuities making them «invisible» to ultrasound.

One can avoid problems with a coupling medium and its negative effect on the detection of surface and subsurface defects by using the electromagnetic acoustic transducer (EMAT).

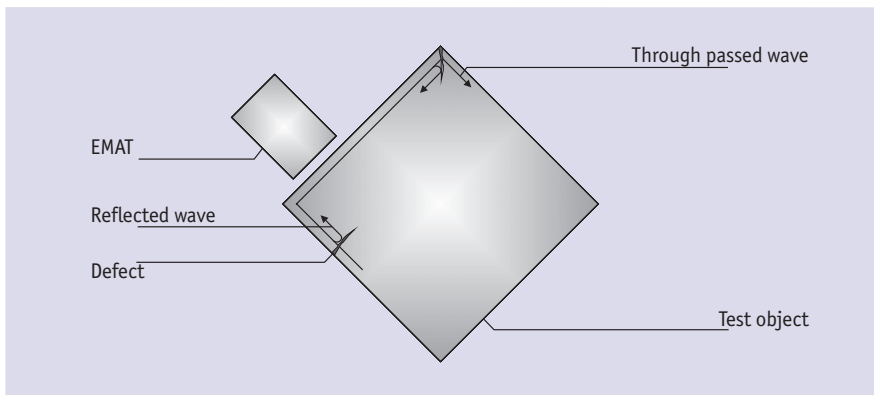

Fig. 1. Detection of surface and subsurface defects using Rayleigh waves.

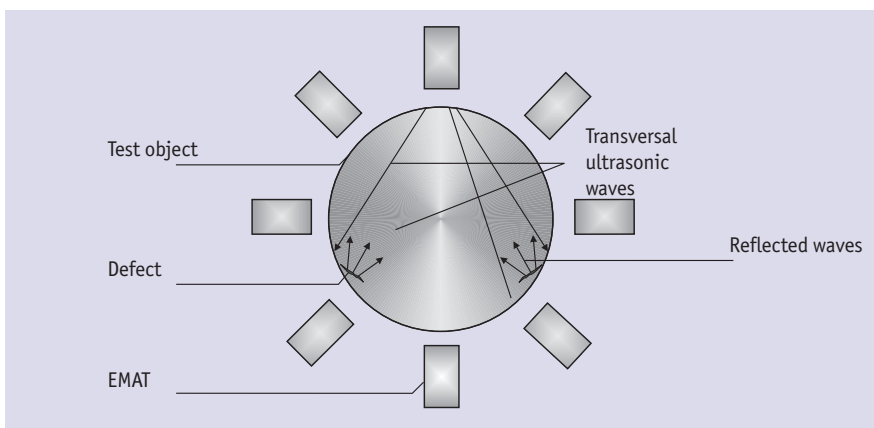

Fig. 2. Detection of surface and subsurface defects using bulk waves.

ULTRASONIC TESTING TECHNOLOGIES USED AND DEVELOPED BY NORDINKRAFT

The most common methods of detecting surface and subsurface flaws are based on the use of Rayleigh and bulk waves, which are generated at an angle to the surface. In order to effectively use these methods in high-performance ultrasonic testing, it is best to deal with non-contact methods of exciting and receiving ultrasonic waves.

The pictures below show EMATs as emitters and receivers of elastic vibrations.



Besides the EMAT, it is possible to apply other devices provided that they can excite and receive ultrasound in a «noncontact» way. One of such devices, for example, is a Laser-EMAT pair. Moreover, the laser is highly effective for exciting elastic vibrations. The EMAT provides effective noncontact reception as a rule.

A combination of several non-destructive testing methods allows one to obtain a qualitatively new result. For instance, the ultrasonic and magnetic-flaw detection techniques can be used in combination for the detection of surface and subsurface defects in bars and billets (see Fig.3).

A permanent magnetic field formed by a ring of permanent magnets «belts» the cross-section of a test object. A ring of receiver coils is located in immediate proximity in the area of maximum concentration of magnetic force lines.

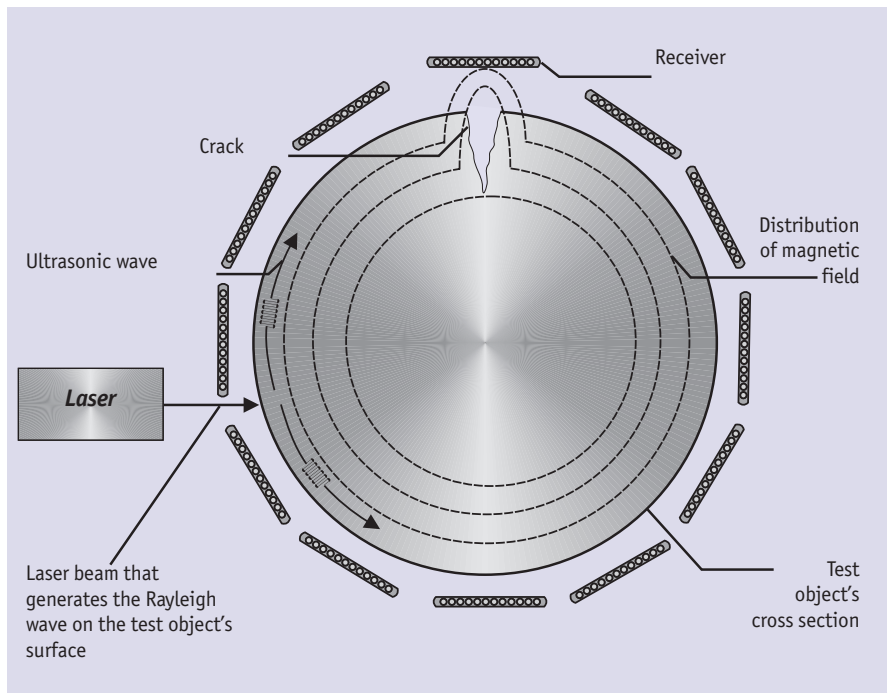

Fig. 3. Detection of surface defects by registering magnetic stray fields caused by the interaction of the Rayleigh wave with a defect.

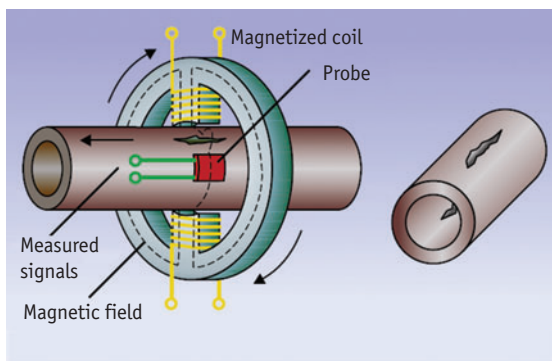

Fig. 4, a. Detection of cracks using magnetic-flaw detection method.

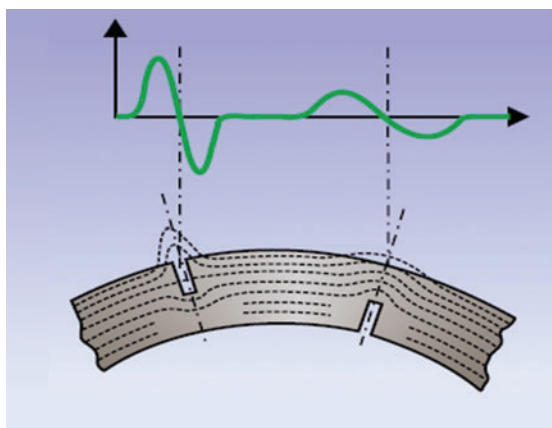

Fig. 4, b. Distortion of magnetic field in defect area.

The Rayleigh wave generated by the laser spreads over the surface of a test object and induces secondary electromagnetic disturbance at flaws' boundaries. If there is a defect, the corresponding coil receives a high-power pulse, the amplitude and spectrum of which allow us to evaluate the size and depth of a flaw.

A well-known surface defects detection pattern for bars and pipes with the use of a device that realizes the magnetic-flaw detection method is given for comparison (see Fig. 4). It is known as «Defectomat» and manufactured by the German company «Institut Dr. FOERSTER».

Magnetic disturbance is created with the help of rotating electromagnets. Receiving coils are located in the area of maximum concentration of magnetic force lines. Therefore, magnetic disturbance is transported by means of mechanical movement (rotation) of magnetic heads. It is easy to calculate that the speed of such transport is slower than when one uses the Rayleigh wave at least to the power of two (in one hundred times!). It is especially important in the case of high-speed inspection. Besides, high capability of the equipment allows one to obtain multiple detection of a short defect at a high speed. This sufficiently increases the noise immunity of inspection and reliability of results.

Combined and magnetic methods have almost the same sensitivity.

The advantage of a device that uses the combined method of surface flaws detection is that it is simple and has no mechanically rotating parts. This improves the device's reliability and sufficiently enhances the area of its application: it can be used both for bars (round) and billets (square). Or even for a cross-section of any shape.

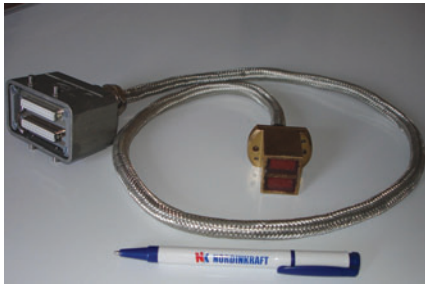

Fig. 5. 16-element TR transducer – piezo electric phased array.

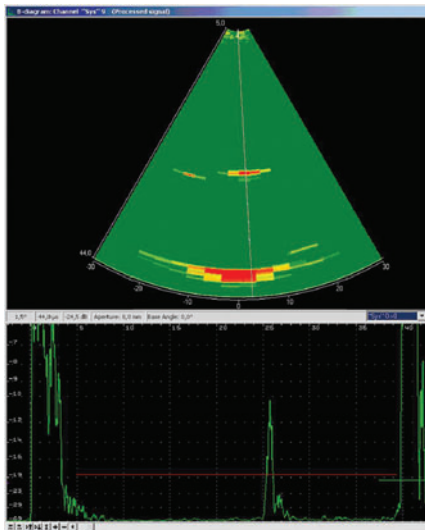

Fig. 6. Defects and waveform of signal from a piezoelectric phased array probe when performing sector scanning of a test object's cross-section.



Fig. 7. $\varnothing 115$ mm bar. Non-metallic inclusions.

NORDINKRAFT is permanently improving and developing «good old technologies» based on the use of the piezoelectric transducer. Moreover, we try to lessen the inconveniences connected with a coupling medium as much as possible.

Successful development of the phased array technology allowed us to significantly simplify the configuration and design of test module and reduce the number of ultrasonic transducers.

Creation of multiple «virtual» channels, more sophisticated test electronics and state-of-the-art software have made it possible.

Figures 5, 6 and 7 show a phased array transducer, a scan from a billet with natural defects and a defect cross section.

We have developed and put into operation an alternative non-contact solution to the full-coverage testing of round and square bars. The solution implies using a group EMAT that can create a virtually rotating ultrasonic field. The principle of virtual rotation of the ultrasonic field and the arrangement of EMATs relative to the test object are shown in Fig. 9.

A widely used configuration that uses an immersion reservoir with rotating piezoelectric transducers is given here for comparison (see Fig. 8). The result being the same, the system produced by NORDINKRAFT is significantly easier to operate, does not need a couplant and any adjustment in a wide range of diameters.

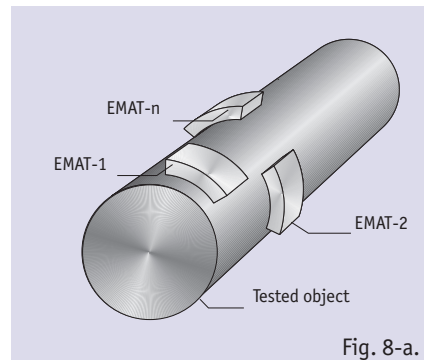

Fig. 8-a.

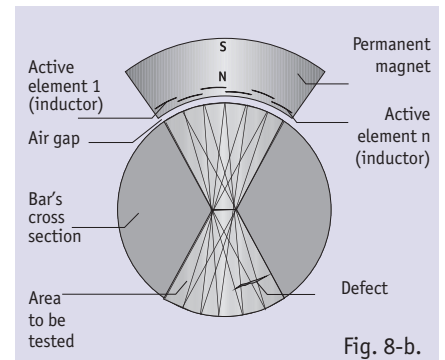

Fig. 8-b.

Fig. 8. Device that uses a group EMAT:
Fig. 8-a. Arrangement of EMAT units.
Fig. 8-b. Principle of virtual rotation of ultrasonic field.

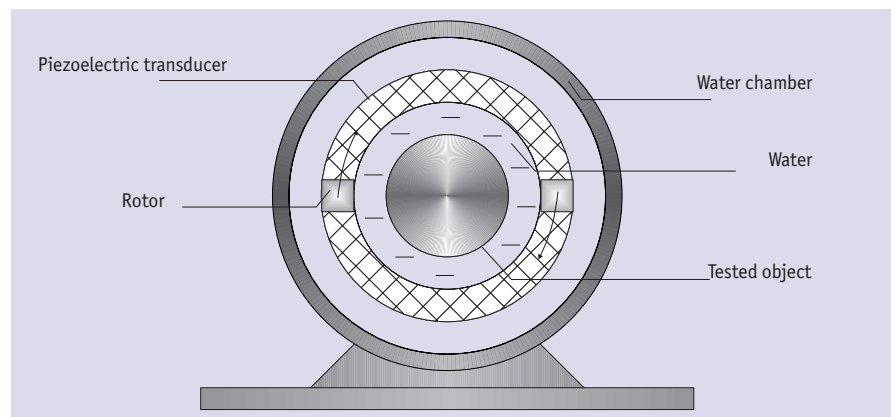

Fig. 9. System with an immersion reservoir and rotating piezoelectric transducers.



EQUIPMENT FOR AUTOMATED ULTRASONIC TESTING OF BARS AND BILLETS «EMATEST-BB»

The systems under the name of «EMATEST-BB» are modern fully automated test equipment that provides 100% ultrasonic inspection of the surface and internal section of bars and billets.

The systems conform with Russian and international standards: GOST 21120-75, GOST 4543-71, GOST 1050-88, SEP 1920, SEP 1921, EN 10228-3, EN 10084, BS 970, ASTM A350 etc.

If it is required to inspect square cross-sections, the system will have four test modules. It takes just a few minutes to turn from one type of test object to another.

Rayleigh waves are usually used to detect surface defects. They are generated and received with the help of non-contact electro-magnetic acoustic transducers.

Among all known types of ultrasonic transducers only the EMAT generates and receives «ideal» (from the point of view of acoustic field's characteristics) surface waves. This fact in many respects explains their high efficiency in detecting surface and subsurface defects.

Besides Rayleigh waves, one can use bulk waves to detect surface and subsurface flaws.

The configuration of such a system assumes that the following patterns will be used: «Laser-EMAT» or «EMAT- EMAT».

For the detection of internal flaws one can apply either the EMAT that emits and receives transversal ultrasonic waves («dry» variant) or

piezoelectric phased arrays that emit and receive bulk waves («wet» variant).

What is remarkable about the phased array probe that it makes possible to control the angles of excitation and reception of ultrasound. It allows one to solve the task of full coverage ultrasonic testing in the best way.

On the other hand, the use of the EMAT gives us the opportunity to avoid water and perform testing at low (below zero) and high (up to +650 °C) temperatures.

The type of transducer depends on the customer and production conditions.

Every «EMATEST-BB» system is certified by GOSSTANDART of Russia and similar authorities of the Ukraine and Byelorussia.

TYPICAL COMPOSITION OF A «EMATEST-BB» SYSTEM

A «EMATEST-BB» system usually consists of the following elements:

- Test unit with EMATs of the surface defects testing system (STS).
- Test unit with EMATs or PETs of the internal defects testing system (ITS).
- Test electronics of STS.
- Test electronics of ITS.
- UT computer.
- Automatics and power supply.
- Draw-out and pressure equipment.
- Defect markers.
- Pneumatic and electric drives.

The control computing system (CCS) controls information flows, organizes the testing process, collects, processes, presents and stores data.

The CCS organizes the testing process in accordance with international standards. They are entered from an augmentable list that contains the names of standards or technical specifications by the operator.

As an option, the system can be added with some necessary mechanical equipment:

- loading trays;
- loaders;
- input conveyor;
- output conveyor;
- sorting device;
- trays for tested products.

The system can easily join any existing production line, or it can be mounted in a separate area.



EMASCAN'S-BB GEOGRPHY

In the last ten years NORDINKRAFT has manufactured and implemented nine «EMATEST-BB» systems.

Eight of them operate at metallurgical enterprises of Russia, Byelorussia and the Ukraine: JSC «SeverStal», JSC «Oskol Electrometallurgical Plant», JSC «Mechel», JSC «Isteel Ukraine», RUE «Byelorussian Steel Works».

One of the systems of this type was created in cooperation with Institut Dr. FOERSTER (Germany) and received the name of «CIRCOSON F R100». It is successfully running at Ovako Steel (Sweden).

A «EMATEST-BB» demo-unit is represented at Institut Dr. FOERSTER in Reutlingen (Germany).



Fig. 12. EMATEST-BB-7 – Severstal, Cherepovets (Russia).



Fig. 10. EMATEST-BB-7 for round and square bars – Byelorussian Steel Works, Zhlobin (Byelorussia).



Fig. 13. Emsacan-BB-6 – Workshop of Institut Dr. FOERSTER (Germany).



Fig. 11. EMATEST-BB-7 – Mechel, Chelyabinsk (Russia).



Fig. 14. EMATEST-BB-9 – Isteel-Ukraine, Donetsk (Ukraine).





Fig. 15. EMATEST-BB-6. Workshop of Nordinkraft. The system was produced for Mechel, Chelyabinsk (Russia).

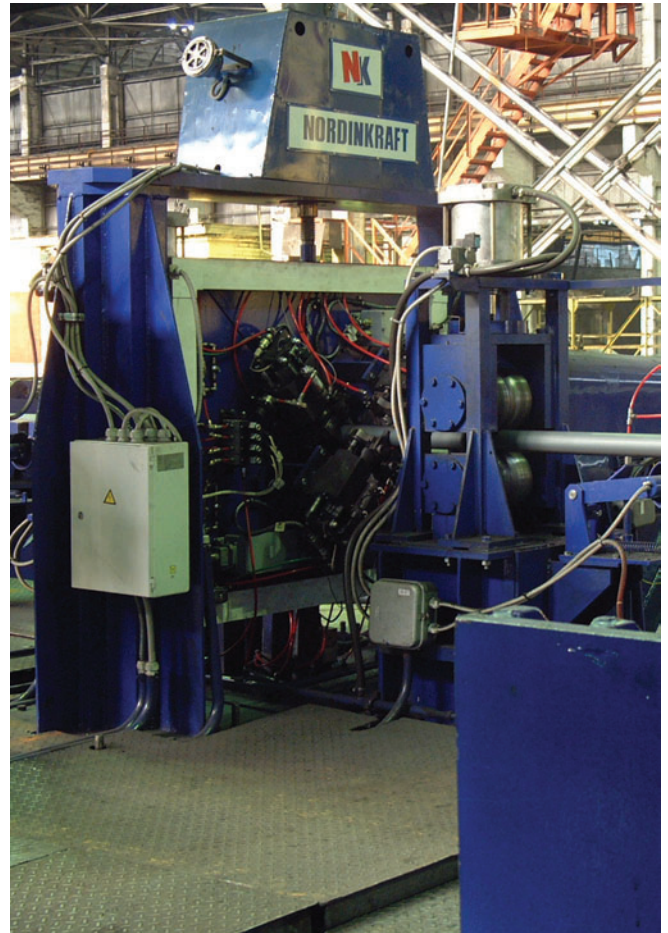

Fig. 16. EMATEST-BB-6 – Severstal, Cherepovets (Russia).

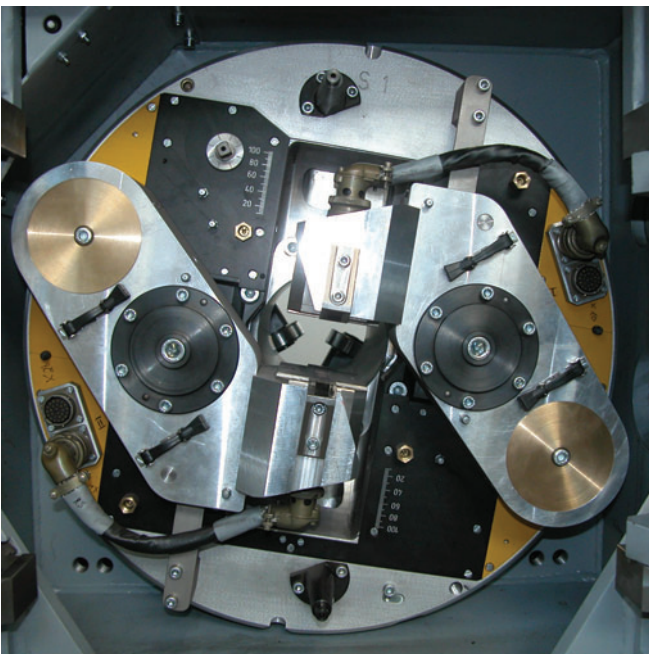

Fig. 17. Rotating head with two 8-channel EMATs – Ovako Steel (Sweden).

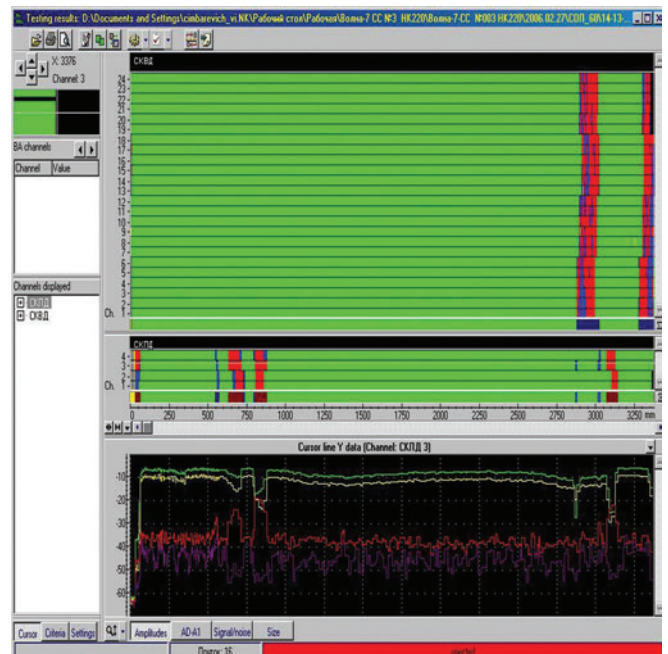

Fig. 18. B-scan from a square billet.



NORDINKRAFT AG
NDT Systems
Christophallee 24
D-75177 Pforzheim
Telephone: + 49 7231-15 556 0
Fax: + 49 7231-15 556 29
E-mail: info@nordinkraft.de

www.nordinkraft.de